

JERR-DAN[®]

Operation And Safety Manual

Original Instructions

Keep this manual with machine at all times.

ADJUSTABLE PERFORMANCE COUNTERWEIGHT

SUPPLEMENTAL MANUAL

5376000182

March 1, 2017

JERR-DAN[®]

An Oshkosh Corporation Company

REVISION LOG

March 1, 2017 - 0 - Original Issue of Manual. CN 164269

Read This First

This manual provides supplemental Operational and Safety information for the Adjustable Performance Counterweight. Read this manual and the Operation and Safety Manual provided with other equipment thoroughly prior to starting operation.

This manual is a very important tool! Keep it with the machine at all times.

The purpose of this manual is to provide owners, users, and operators with the precautions and operating procedures essential for the safe and proper machine operation for its intended purpose.

Due to continuous product improvements, Jerr-Dan Corporation reserves the right to make specification changes without prior notification. Contact Jerr-Dan Corporation for updated information.

OPERATOR QUALIFICATIONS

The operator of the machine must not operate the machine until this manual has been read, training is accomplished and operation of the machine has been completed under the supervision of an experienced and qualified operator.

Operators of this equipment must possess a valid, applicable driver's license, be in good physical and mental condition, have normal reflexes and reaction time, good vision and depth perception and normal hearing. Operator must not be using medication which could impair abilities nor be under the influence of alcohol or any other intoxicant during the work shift.

In addition, the operator must read, understand and comply with instructions contained in the following material furnished with the equipment:

- This Operation & Safety Manual
- All instructional decals and plates
- Any optional equipment instructions furnished
- Commercial vehicle's Operation & Maintenance Manuals

The operator must also read, understand and comply with all applicable Employer, Industry and Governmental rules, standards and regulations.

MODIFICATIONS

Any modification to this machine must be approved by Jerr-Dan.

HAZARD CLASSIFICATION SYSTEM

SAFETY ALERT SYSTEM AND SAFETY SIGNAL WORDS



This is the Safety Alert Symbol. It is used to alert you to the potential personal injury hazards. Obey all safety messages that follow this symbol to avoid possible injury or death.



Indicates an imminently hazardous situation. If not avoided, will result in serious injury or death. This decal will have a red background.



Indicates a potentially hazardous situation. If not avoided, could result in serious injury or death. This decal will have an orange background.



Indicates a potentially hazardous situation. If not avoided, may result in minor or moderate injury. It may also alert against unsafe practices. This decal will have a yellow background.



Indicates information or a comply policy that relates directly or indirectly to the safety of the personnel or protection of property.

Read This First

WARNING

This product must comply with all safety related bulletins. Contact Jerr-Dan Corporation or the local authorized representative for information regarding safety bulletins which may have been issued for this product.

NOTICE

Jerr-Dan Corporation sends safety related bulletins to the owner of record of this machine. Contact Jerr-Dan Corporation to ensure that the current owner of records are updated and accurate.

NOTICE

Jerr-Dan Corporation must be notified immediately in all instances where Jerr-Dan product have been involved in an accident involving bodily injury or death of personnel or when substantial damage has occurred to personal property on the Jerr-Dan product.

FOR:

- Accident Reporting and Product Safety Publications
- Current Owner Updates
- Questions Regarding Product Applications and Safety
- Standards and Regulations Compliance Information
- Questions Regarding Product Modifications

CONTACT:

Product Safety and Reliability Department
Jerr-Dan Corporation
13224 Fountainhead Plaza
Hagerstown, MD 21742
USA

or Your Local Jerr-Dan Office

In USA

Toll Free: 1-877-554-7233

Outside USA

Phone: 240-420-2661

Fax: 301-745-3713

E-mail

ProductSafety@Jerr-Dan.com

REPORTING SAFETY DEFECTS

If you believe that your vehicle has a defect which could cause a crash or could cause injury or death, you should immediately inform the National Highway Traffic Safety Administration (NHTSA) in addition to notifying Jerr-Dan Corporation.

If NHTSA receives similar complaints, it opens an investigation, and if it finds that a safety defect exists in a group of vehicles, it may order a recall and remedy campaign. However, NHTSA cannot become involved in individual problems between you, your dealer, or Jerr-Dan Corporation.

To contact NHTSA, you may call the Vehicle Safety Hotline toll-free at 1-888-327-4236 (TTY: 1-800-424-9153; go to <http://www.safercar.gov>; or write to:

Administrator
NHTSA
400 Seventh Street S.W.
Washington, DC 20590

You can also obtain other information about motor vehicle safety from <http://www.safercar.gov>.

THIS PAGE IS INTENTIONALLY LEFT BLANK

TABLE OF CONTENTS

Revision Log

Read This First

Operator Qualifications	b
Modifications	b
Hazard Classification System	c
Safety Alert System And Safety Signal Words	c
Reporting Safety Defects.....	e

Table of Contents

Section 1 - General Safety Practices

1.1	General	1-1
1.2	Pre-operation	1-2
	Operator Training And Knowledge	1-2
	Crush And Collision Hazards	1-3
	Fall Hazards	1-3
	Chemical Hazards	1-4
	Battery Hazards	1-5
	Personal Protective Equipment	1-5
	Weather Conditions	1-6
	Vehicle Equipment Damage	1-6

Section 2 - Pre-operation And Inspection

2.1	Pre-operation Check And Inspection	2-1
2.2	Decals	2-2
2.3	Walk-around Inspection	2-3
2.4	Operational Checks	2-5

Section 3 - Controls & Indicators

3.1	General	3-1
3.2	Controls	3-2
	Electrical Controls - Passanger Side	3-2
	Manual Controls - Passanger Side	3-2

Section 4 - Operation

4.1	Counterweight Operation	4-1
4.2	Adding Additional Weight	4-2
4.3	Removing Weight	4-5

Section 5 - Manual Pump Operation

5.1	Raising/Lowerereng the Counterweight	5-1
-----	--	-----

Table of Contents

Section 6 - Maintenance

	Introduction	6-1
6.1	Maintenance And Lubrication	6-2
6.2	Oils	6-2
6.3	Trouble Shooting	6-3
	Hydraulic System	6-3
	Hydraulic Pump	6-4

Section 7 - Specifications

7.1	Product Specifications	7-1
7.2	Capacities	7-1

Inspection, Maintenance and Repair Log

Transfer of Ownership

SECTION 1 - GENERAL SAFETY PRACTICES

1.1 GENERAL

This section outlines the necessary precautions for proper and safe machine operation and maintenance. For proper machine use, it is mandatory that a daily routine is established based on the content of this manual. A maintenance program, using the information provided in this manual must also be established by a qualified person and followed to ensure the machine is safe to operate.

The owner/user/operator of the machine must not operate the machine until this manual has been read, training is accomplished, and operation of the machine has been completed under the supervision of an experienced and qualified operator.

There may be times your truck may be exposed to direct contact with the public such as parades, charitable fundraisers, etc. Before allowing anyone other than a trained and experienced employee of your company near your truck, you should consult with your company safety officer and plan for safety.

If there are any question with regard to safety, training, inspection, maintenance, application, and operation, please contact Jerr-Dan Corporation.

WARNING

Failure to comply with the safety precautions listed in this manual could result in machine damage, property damage, personal injury or death.

Section I - General Safety Practices

1.2 PRE-OPERATION

OPERATOR TRAINING AND KNOWLEDGE

- Read and understand this manual before operating the machine.



- Do not operate this machine until complete training is performed by authorized persons.
- Only authorized and qualified personnel can operate the machine.
- Read, understand, and obey all DANGERS, WARNINGS, CAUTIONS, and operating instructions on the machine and in the manual.
- Use the machine in a manner which is within the scope of its intended application set by Jerr-Dan.
- All operating personnel must be familiar with the emergency operation of the machine as specified in this manual.
- Read, understand, and obey all applicable employer, local, and government regulations as the pertain to the operation of the machine.

CRUSH HAZARDS



- Look out for and avoid other personnel, machinery, vehicles and obstructions in the area when driving the truck. Use a spotter if you DO NOT have a clear view.
- Stand clear of the counterweight to avoid crushing injury. Area should be clear of feet when raising or lowering the counterweight. Also, never move the vehicle with the counterweight lowered in the truck chassis service position

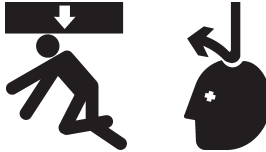

- Use only safe practices when maintaining this equipment. Always turn off the ignition switch before reaching into pinch areas.



FALL HAZARDS

- DO NOT carry riders outside the cab. Riders could fall off the machine.
- Do not climb on the truck to access elevated service points. Only use approved ladders or grab handles and steps provided on the rear of the unit when accessing the service points on the top of the truck body in a controlled service environment. Always maintain 3-point contact, using two hands and one foot or two feet and one hand, when mounting or dismounting. These surfaces can become slippery, ensure to keep them and footwear clean and free of debris.

Section I - General Safety Practices

CHEMICAL HAZARDS

Exhaust Fumes

- DO NOT operate machine in an enclosed area without proper ventilation.
- DO NOT operate the machine in hazardous environments unless approved for that purpose by Jerr-Dan and site owner. Sparks from the electrical system and the engine exhaust can cause an explosion.

Flammable Fuel



- DO NOT attempt to repair or tighten any hydraulic hoses or fittings while the engine is running or when the hydraulic system is under pressure.

Hydraulic Fluid



- Stop engine and relieve trapped pressure. Fluid in the hydraulic system is under pressure and can penetrate the skin.
- DO NOT use your hand to check for leaks. Use a piece of cardboard or paper to search for leaks. Wear gloves to protect hands from spraying fluid.

BATTERY HAZARDS



- Battery fluid is highly corrosive. Avoid contact with skin and clothing at all times.
- Keep sparks, flames, and lighted materials away from batteries.
- Charge batteries only in a well ventilated area.
- Wear proper eye protection when servicing battery.

PERSONAL PROTECTIVE EQUIPMENT



- Use personal protective equipment when working on or around this vehicle.
- Remove rings, watches, jewellery, neckwear or other items that can catch in equipment.
- Wear :
 - Snug fitting and sturdy long-sleeve shirt and long pants. Avoid loose fitting clothes.
 - Sturdy gloves.
 - Approved eye protection.
 - Steel toed boots.
 - Approved head gear.
 - Approved hearing protection.

Section I - General Safety Practices

WEATHER CONDITIONS



- If using in freezing conditions, you must be alert to possibility of ice forming on the device. Use Caution when raising and lowering the counterweight.
- Hydraulic cylinders are subject to thermal expansion and contraction. This may result in changes to the counterweight position while the machine is stationary. Factors affecting thermal movement can include the length of time the machine is stationary, hydraulic oil temperature, and ambient air temperature.

VEHICLE EQUIPMENT DAMAGE

- Do not move the vehicle while rear counterweight is lowered.
- **Do not use machine as a ground when performing any welding operations.**

SECTION 2 - PRE OPERATION AND INSPECTION

2.1 PRE-OPERATION CHECK AND INSPECTION

Note: Complete all required maintenance before operating unit.

⚠ WARNING

FALL HAZARD. Use extreme caution when checking items beyond your normal reach. Use an approved ladder.

The pre-operation check and inspection, performed at beginning of each work shift or at each change of operator, should include the following:

1. **Cleanliness** - Check all surfaces for leakage (oil, fuel or battery fluid) or foreign objects. Report any leakage to the proper maintenance personnel.
2. **Structure** - Inspect the machine structure for dents, damage, weld or parent metal cracks or other discrepancies.
3. **Safety Decals Placards** - Ensure all decals are legible and in place. Clean or replace as required. See page 2-2 for details.
4. **Operation and Safety Manual(s)** - Operation & Safety Manual(s) are in cab.
5. **Walk-Around Inspection** - See page 2-3 for details.
6. **Attachments** - Inspect attachments for dents, damage, weld or parent metal cracks or other discrepancies.
7. **Operational Check** - Once the walk-around inspection is complete, perform an operational check (see page 2-5) of all systems in an area free of ground level obstructions. See Section 3 - Controls and Indicators for more specific operating instructions.

⚠ WARNING

If your counterweight does not operate properly, immediately bring machine to a stop, lower boom to stowed position and stop the engine. Determine cause and correct before continued use.

2.3 WALK-AROUND INSPECTION

NOTE: Complete all required maintenance before operating the unit.

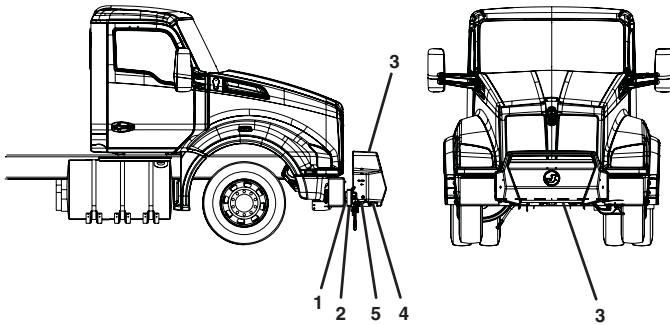

Begin your walk-around inspection at item 1, as noted below checking each item in sequence.

INSPECTION NOTE: On all components, make sure there are no loose or missing parts, that they are securely fastened and no visible leaks or excessive wear exists in addition to any other criteria mentioned. Inspect all structural members including attachment for cracks, excessive corrosion and other damage.

⚠ WARNING

FALL HAZARD. Use extreme caution when checking items beyond your normal reach. Use an approved ladder.

⚠ CAUTION

All products are subject to age, wear and deterioration, all of which cause a reduction in the products breaking strength capacity. It is recommended that all products be regularly inspected to follow component manufacturer's recommendations. Any worn, deformed, misused or overloaded products must be replaced immediately.

Section II : Pre-operation and Inspection

1. Counterweight Adapter Pins – Left Hand and Right Hand
 - a. Check attachment points to front of chassis frame
 - b. Components undamaged
 - c. Check attachment to front of chassis frame, Bolts, secure
 - d. Check attachment to front of chassis frame, Nuts, secure
2. Counterweight Adapter Plate – Left Hand and Right Hand
 - a. Check attachment to front of adapter pins, Bolts, secure
 - b. Components undamaged
3. Counterweight
 - a. Components undamaged
 - b. Pivot Pins, secure
4. Hydraulic Cylinder
 - a. Components undamaged
 - b. Pins, secure
 - c. Hydraulic hoses undamaged, not leaking
5. Hydraulic Power Unit
 - a. Components undamaged
 - b. Hydraulic fluid level full
 - c. Valve not leaking

2.4 OPERATIONAL CHECKS

OPERATIONAL CHECK

1. Electric over hydraulic controlled functions - all functions operate smoothly and the switch returns to the "Neutral Off" position.
2. Manually controlled hydraulic functions - all functions operate smoothly.

CAUTION

Stand clear of the counterweight to avoid crushing injury. Area should be clear of feet when raising or lowering the counterweight. Also, never move the vehicle with the counterweight lowered in the truck chassis service position.

THIS PAGE IS INTENTIONALLY LEFT BLANK

SECTION 3 - CONTROLS & INDICATORS

3.1 GENERAL

This section provides the necessary information needed to understand control functions.

The counterweight is supplied with two methods of operation.

The toggle switch in the counterweight adapter plate controls the hydraulic power unit of the counterweight to control the tilt up and tilt down functions.

There is also a manual pump that allows the user to provide hydraulic power to the cylinder should the electrical system fail to operate.

Note: The manufacturer has no direct control over machine application and operation. The user and operator are responsible for conforming with good safety practices.

Section III - Controls & Indicators

3.2 CONTROLS

ELECTRIC CONTROLS - PASSANGER SIDE

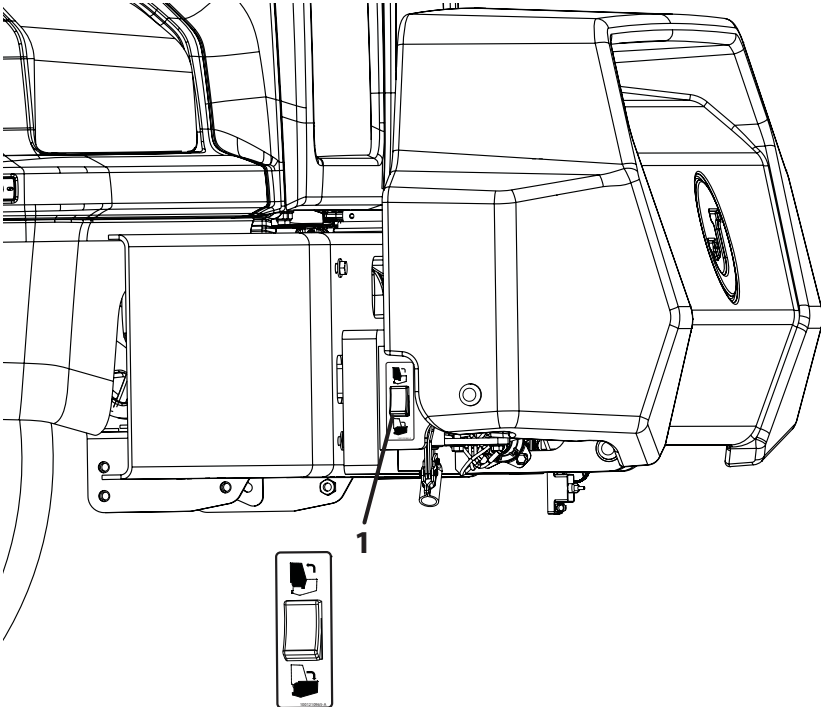

1. Pump Control Rocker Switch : Engages the pump to control the Tilt Up/Down functions of the Counterweight.

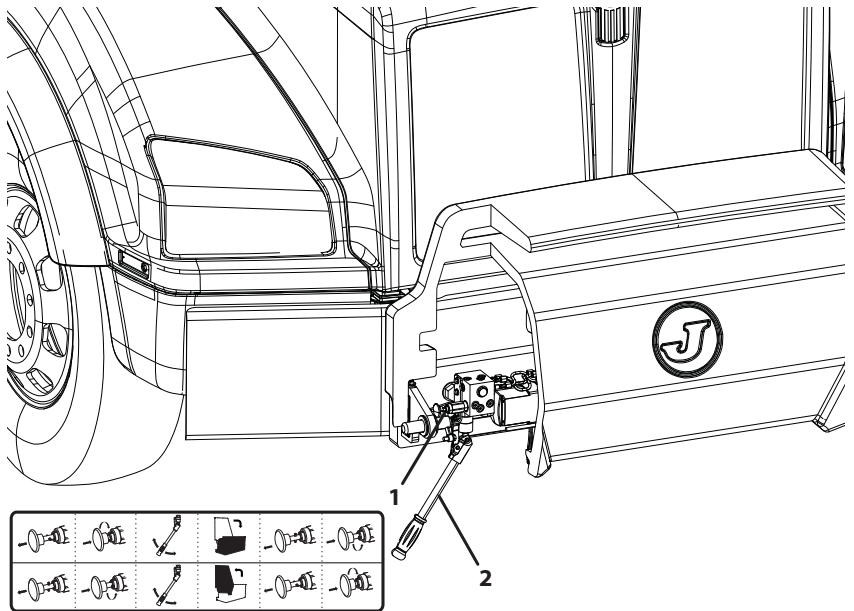

1. Manual Valve Control

: The manual control valve selects the Tilt Up/Down functions of the Counterweight.

2. Hand Pump

: Manually pumps hydraulic fluid to the control valve

THIS PAGE IS INTENTIONALLY LEFT BLANK

SECTION 4 - OPERATION

The primary operator control is located on the right side of the counterweight mounting bracket.

4.1 COUNTERWEIGHT OPERATION

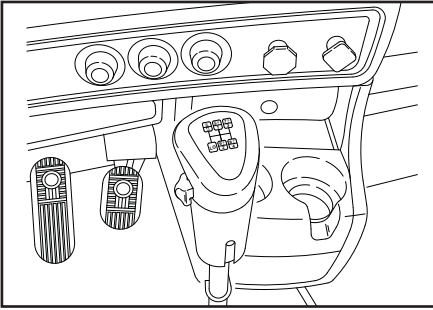

1. Turn on the ignition to the truck chassis to provide power to the counterweight power unit.

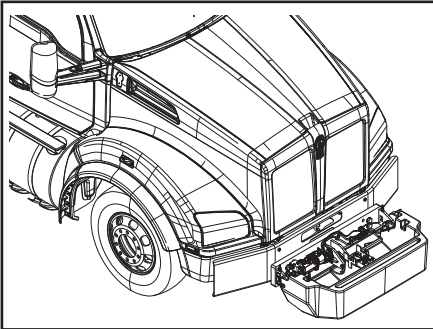

2. Push the control rocker switch into the down position to lower the counterweight into the truck chassis service position.

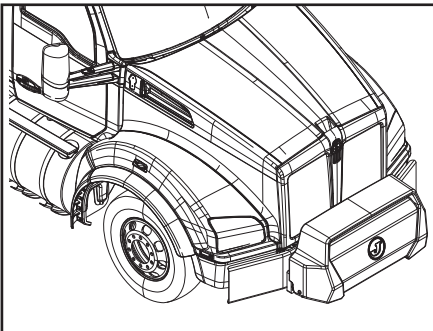

3. Push the control rocker switch into the up position to raise the counterweight into the truck chassis running position..

NOTICE

Electric motor is not intended for continuous use. Allow a minimum of 3 minutes between up/down cycles for motor to cool.

⚠ CAUTION

Stand clear of the counterweight to avoid crushing injury. Area should be clear of feet when raising or lowering the counterweight. Also, never move the vehicle with the counterweight lowered in the truck chassis service position.

Section IV : Operation

The operator may occasionally need to adjust the counterweight by adding or removing weight plates in the Adjustable Performance Counterweight.

Small Weight Plates.....97 lb each (Approx.)

Large Weight Plates 119 lb each (Approx.)

DO NOT EXCEED THE CHASSIS FRONT AXLE WEIGHT RATING (GAWR)

4.2 ADDING ADDITIONAL WEIGHT

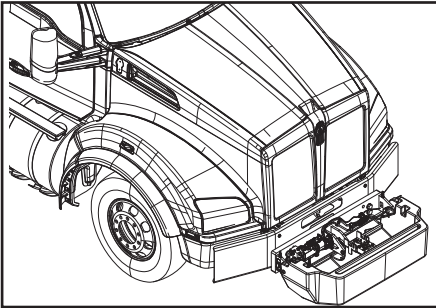

1. Push the control rocker switch into the down position to lower the counterweight into the truck chassis service position.

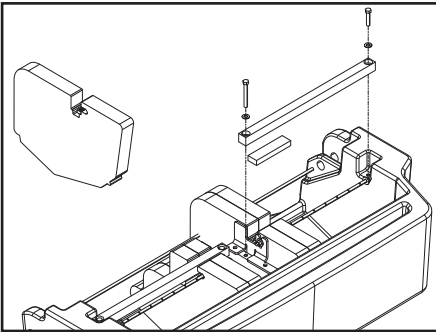

2. Remove the steel retaining bars and poly spacers by removing the capscrews and flatwashers from each end of the weight stack.

Section IV : Operation

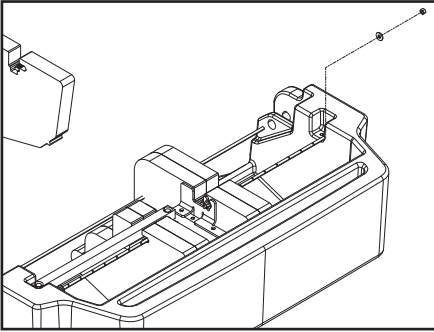

3. Remove the locknut and washer from the outboard end of the threaded rod. Slide the threaded rod inboard to allow weight plates to be added between the end of the rod and the adjustable performance counterweight casting.

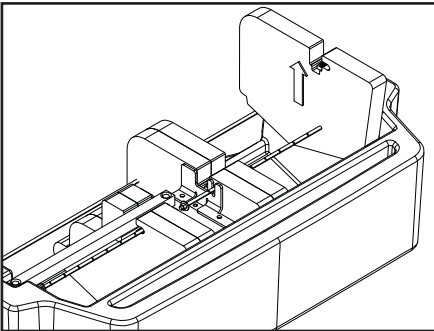
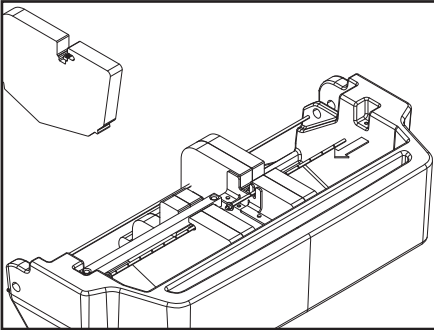

4. Place a threaded device such as an eyebolt into the 0.50-13NC nut welded onto the weight plate to assist with lifting.
5. Using an appropriate lifting device, lift and place the weight plate(s) into the adjustable performance counter weight casting, working from the center outward. *Small weight plates get installed into the passenger side of the counterweight and the large weigh plates get installed into the driver side of the counterweight.*

Section IV : Operation

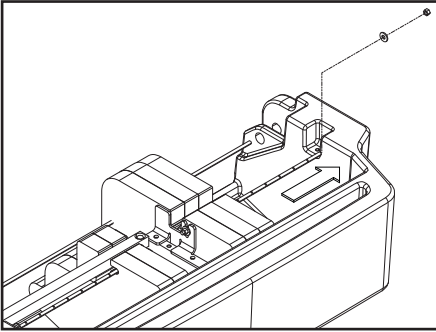

6. Slide the threaded rod outward so the inboard nut is against the center bracket. Reinstall and tighten the locknut and washer from the outboard end of the threaded rod to hold the plates together.

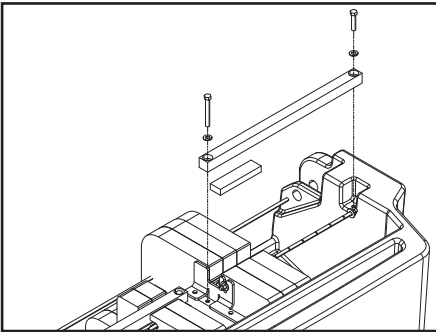

7. Reinstall the steel retaining bars and poly spacers and secure with the capscrews and flatwashers at the end of each weight stack. The 2" bolts go in the outboard end, and the 3-1/2" bolts go into the inboard end. *Tighten the capscrews enough to compress the poly spacers but minimizing deflection of the retaining bars.*

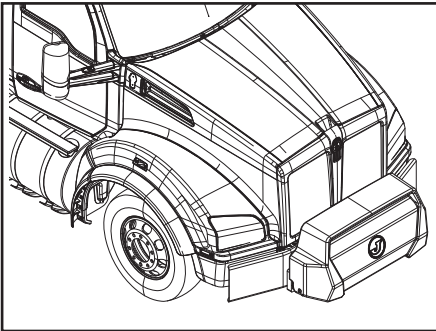

8. Push the control rocker switch into the up position to raise the counterweight into the truck chassis running position.

4.3 REMOVING WEIGHT

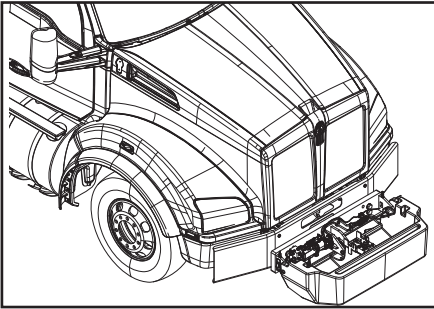

1. Push the control rocker switch into the down position to lower the counterweight into the truck chassis service position.

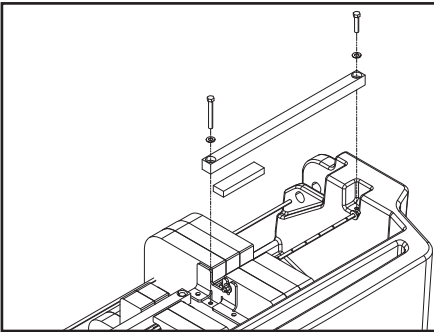

2. Remove the steel retaining bars and poly spacers by removing the capscrews and flatwashers from each end of the weight stack.

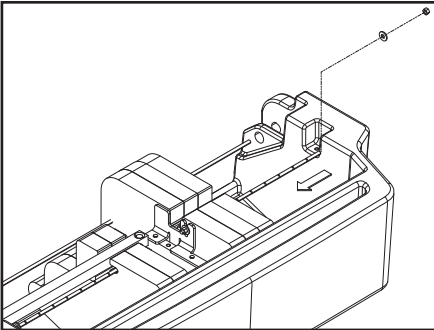

3. Remove the locknut and washer from the outboard end of the threaded rod. Slide the threaded rod inboard to allow weight plates to be removed between the end of the rod and the adjustable performance counterweight casting.

4. Place a threaded device such as an eyebolt into the 0.50-13NC nut welded onto the weight plate to assist with lifting.

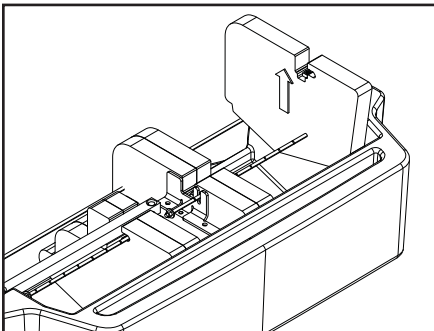

5. Using an appropriate lifting device, lift and remove the weight plate(s) from the adjustable performance counter weight casting.

Section IV : Operation

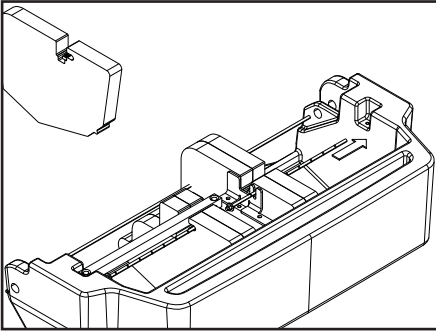

6. Slide the threaded rod outward so the inboard nut is against the center bracket. Reinstall and tighten the locknut and washer from the outboard end of the threaded rod to hold the plates together.

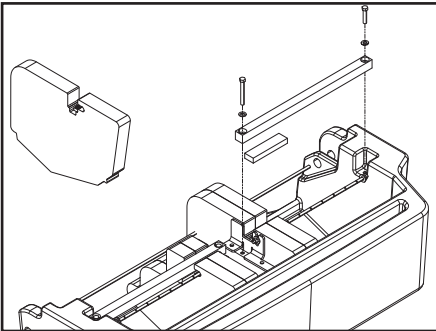
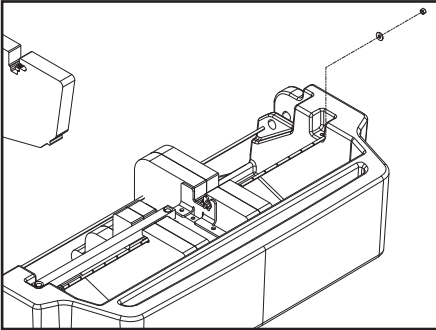

7. Reinstall the steel retaining bars and poly spacers and secure with the capscrews and flatwashers at the end of each weight stack. The 2" bolts go in the outboard end, and the 3-1/2" bolts go into the inboard end. *Tighten the capscrews enough to compress the poly spacers but minimizing deflection of the retaining bars.*

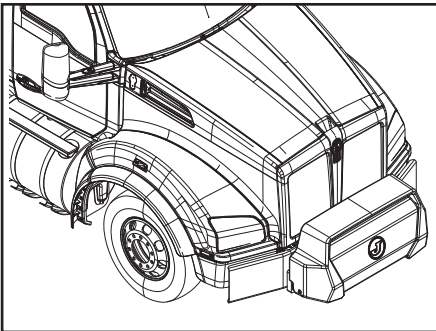

8. Push the control rocker switch into the up position to raise the counterweight into the truck chassis running position.

SECTION 5 - MANUAL PUMP OPERATION

5.1 RAISING/LOWERING THE COUNTERWEIGHT

In the event of total loss of electrical power or hydraulic pump failure of the counterweight, the situation must be properly evaluated and dealt with on an individual basis.

Operate the unit using the following procedures:

To Lower the Counterweight:

1. Pull out and rotate manual selector valve knob clockwise and seat in the retracted position.
2. Use handle to manually pump the cylinder, lowering the counterweight.
3. Pull out and rotate manual selector valve knob counterclockwise into the extended position.

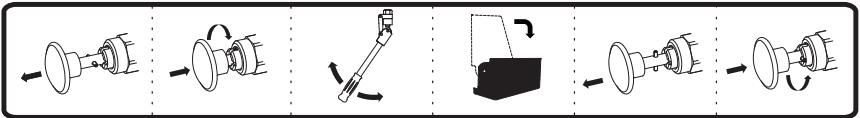

To Raise the Counterweight:

1. Pull out and rotate manual selector valve knob counterclockwise and seat in the extended position.
2. Use handle to manually pump the cylinder, raising the counter.
3. Pull out and rotate manual selector valve knob clockwise into the retracted position

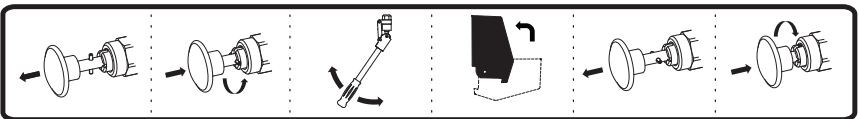

⚠ CAUTION

Stand clear of the counterweight to avoid crushing injury. Area should be clear of feet when raising or lowering the counterweight. Also, never move the vehicle with the counterweight lowered in the truck chassis service position.

THIS PAGE IS INTENTIONALLY LEFT BLANK

SECTION 6 - MAINTENANCE

INTRODUCTION

Service the product in accordance with the maintenance schedule on the following pages.

Wear all the protective clothing and personal safety devices issued to you or called for by job conditions.

DO NOT wear loose clothing or jewelry that can get caught on controls or moving parts.

Intervals shown are for normal usage and conditions. Adjust intervals for abnormal usage and conditions.

Check all lubricant levels when lubricant is cool. For ease of filling hydraulic reservoir, use a funnel with a hose or flexible tube for best results.



Use only safe practices when maintaining this equipment. Always turn off the ignition switch before reaching into pinch areas.

Place Do Not Operate Tags on the ignition switch and the steering wheel before attempting to perform any service or maintenance. Remove the key and disconnect battery leads.

! WARNING

CUT/CRUSH/BURN HAZARD. Do not perform service or maintenance on the machine with the engine running, with the exception of the hydraulic return filter indicator checks.

! WARNING

The hydraulic system operates at extremely high and potentially dangerous pressures. The operator must relieve any system pressure before disconnecting or removing and portion of the system.

Section VI - Maintenance

6.1 MAINTENANCE AND LUBRICATION

There are a number of different lubricants used on your Adjustable Performance Counterweight. The following Chart shows the proper lubricant and the most common brands and specification which meet the requirements. Refer to Section 6.2.

6.2 OILS

The following oils are suitable for use with your Jerr-Dan Product.

Company	Product
HYDRAULIC OILS	
1. Chevron	AW Hydraulic Oil MV
2. Exxon	Univis N32
3. Shell	Tellus STX32
4. Texaco	Rando HDZ-32
5. Kendall	Golden MV ISO 32
6. Citgo	Transguard Low-Temp 32
7. Coastal	AW 32 MV
8. Mobil	DTE10 Excel 32 (for cold weather use)
9. Conoco	AW Hydraulic Fluid MV 32 (for cold weather use)

* Automatic Transmission Fluid may be substituted if necessary.

6.3 TROUBLE SHOOTING

You probably won't require anything but preventive maintenance to keep your Adjustable Performance Counterweight running, however, the following chart should help you isolate and correct minor problems if they occur with use. Any service work on the hydraulic system should be performed by qualified mechanics.

HYDRAULIC SYSTEM

Problem	Cause	Solution
Slow operation	<ul style="list-style-type: none"> a. Low oil level b. Blocked or restricted hose c. Dirty hydraulic oil d. Hydraulic pump worn e. Frozen hydraulic lines 	<ul style="list-style-type: none"> a. Check level and fill with the specified oil b. Inspect: remove blockage c. Drain, flush and refill with clean oil, replace filter d. Rebuild or replace e. Thaw and remove water
Valve leaks	<ul style="list-style-type: none"> a. Defective seals 	<ul style="list-style-type: none"> a. Inspect and replace
Cylinder leaks	<ul style="list-style-type: none"> a. Defective seals or rods 	<ul style="list-style-type: none"> a. Inspect and replace
Erratic cylinder function	<ul style="list-style-type: none"> a. Air in the system b. Defective pump (pulsating) 	<ul style="list-style-type: none"> a. Cycle hydraulic system a few times to remove air b. Replace if necessary
Pump Runs, System unresponsive	<ul style="list-style-type: none"> a. Manual valve control in incorrect position 	<ul style="list-style-type: none"> a. Shift knob to opposite position

Section VI - Maintenance

HYDRAULIC PUMP

Problem	Cause	Solution
Pump noisy (Cavitation)	<ul style="list-style-type: none"> a. Low oil supply b. Heavy oil c. Dirty oil filter d. Restriction in suction line e. Pump worn 	<ul style="list-style-type: none"> a. Fill to proper level b. Fill with proper oil (See chart) c. Replace filter d. Clean out and remove e. Repair or replace
Pump slow or fails to respond	<ul style="list-style-type: none"> a. Low oil supply b. Poor electrical connections c. Motor thermal breaker kicked off d. Tripped circuit breaker e. Cold Thick Oil 	<ul style="list-style-type: none"> a. Fill to proper level b. Check electrical connections c. Allow time to cool, shorten duty cycle d. Reset circuit breaker e. Drain and refill with a low temperature oil
Oil foaming	<ul style="list-style-type: none"> a. Air leaking into suction line b. Wrong kind of oil c. Oil level too low 	<ul style="list-style-type: none"> a. Tighten all connections b. Drain and refill with non-foaming type of hydraulic oil (See suitable oil list) Replace filter c. Refill to proper level
Pump leaks	<ul style="list-style-type: none"> a. Defective seals 	<ul style="list-style-type: none"> a. Replace seals
Oil heating up	<ul style="list-style-type: none"> a. Foreign material lodged in relief valve filter b. Using too light oil c. Dirty oil d. Oil level too low e. Pump worn (slippage) 	<ul style="list-style-type: none"> a. Inspect and remove/replace b. Drain and refill with clean oil c. Drain, flush and refill with clean oil/replace filter d. Fill to proper level e. Repair or replace

SECTION 7 - SPECIFICATIONS

7.1 PRODUCT SPECIFICATIONS

Dimensions

Overall Height	25.25 in
Overall Width	55.50 in
Overall Depth	18 in
Minimum Weight	1,700 lb
Maximum Weight	3,600 lb

7.2 CAPACITIES

Hydraulic System

Operating Pressure	3000 psi max.
System Flow	0.3 gpm
System Capacity	26 cubic inches
Type of Oil	
0° to 104° F	Mobilfluid® 424
-40° to 0° F	Mobile DTE 10 Excel 32M

Electrical System

Electrical System Voltage	12V DC
---------------------------------	--------

THIS PAGE IS INTENTIONALLY LEFT BLANK



An Oshkosh Corporation Company

TRANSFER OF OWNERSHIP

To Product Owner:

If you now own but ARE NOT the original purchaser of the product covered by this manual, we would like to know who you are. For the purpose of receiving safety-related bulletins, it is very important to keep Jerr-Dan Corporation updated with the current ownership of all Jerr-Dan products. Jerr-Dan maintains owner information for each Jerr-Dan product and uses this information in cases where owner notification is necessary.

Please use this form to provide Jerr-Dan with updated information with regard to the current ownership of Jerr-Dan products. Please return completed form to the Jerr-Dan Product Safety & Reliability Department via facsimile or mail to address as specified below.

Thank You,
Product Safety & Reliability Department
Jerr-Dan Corporation
13224 Fountainhead Plaza
Hagerstown, MD 21742
USA
Telephone: +1-717-485-6591
Fax: +1-301-745-3713

NOTE: Leased or rented units should not be included on this form.

Mfg. Model : _____

Serial Number : _____

Previous Owner : _____

Address : _____

Country : _____ Telephone : (_____) _____

Date of Transfer : _____

Current Owner : _____

Address : _____

Country : _____ Telephone : (_____) _____

Who in your organization should we notify?

Name : _____

Title : _____

THIS PAGE IS INTENTIONALLY LEFT BLANK



5376000182- 0

JERR-DAN

An Oshkosh Corporation Company

*13224 Fountainhead Plaza
Hagerstown, MD 21742
Phone (717) 597-7111*

TOW 
SUPPORT
by **JERR-DAN**

Phone (800) 926-9666

www.jerr-dan.com